

Cleaning System

NIKE TL

MICROPROCESSOR TIMED PERISTALTIC PUMP FOR
DETERGENT DOSING



Main characteristics

- TIMED DOSING 0 ÷ 999 SEC. WITH TRIGGER ACTIVATION.
- IDEAL FOR COIN OPERATED MACHINES.
- FIXED FILTER OF 5 SEC ON TRIGGER.
- SETTABLE DELAY ON DOSING ACTIVATION 0 ÷ 999 SEC.
- HOLD TIME SETTABLE ON TRIGGER 0 ÷ 999 MIN.
- PARAMETERS SETTING MENU PROTECTED BY PASSWORD (0 ÷ 999).
- CONTROL OF THE MOTOR AND OF THE INITIAL START UP WITH ALARM IN CASE OF OVERLOAD ON THE MOTOR AND MANAGEMENT OF STARTING ATTEMPT.
- SUITABLE FOR HIGH VISCOUS LIQUID INJECTION.
- IP 65 PROTECTION DEGREE.
- EASY INSTALLATION AND MAINTENANCE.
- POWER SUPPLY 100 ÷ 240 or 24 Vac 50/60hz, TRIGGER 100 ÷ 240 or 24 Vac.
- EPDM OR SILICON PERISTALTIC HOSE Ø 6,25x10,5 mm.
- FLOW RATE 15 L/h - PRESSURE 100 kPa (1 bar - 14,5 psi).
- LOW Level sensor upon request.

Cleaning System

Dimensional drawing

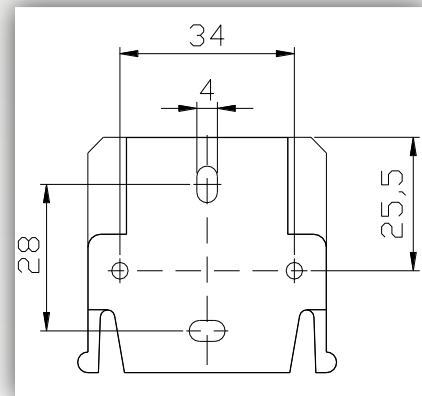
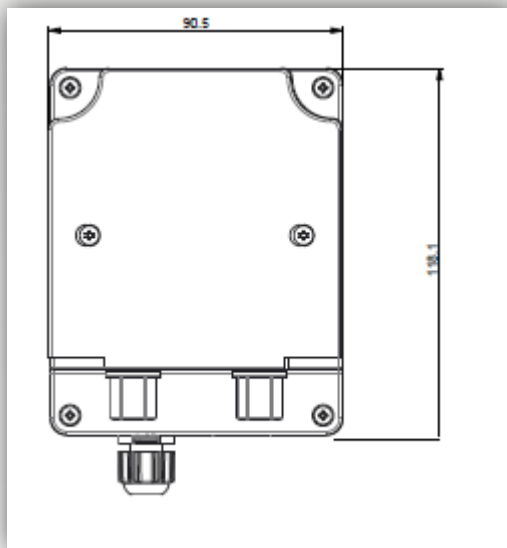
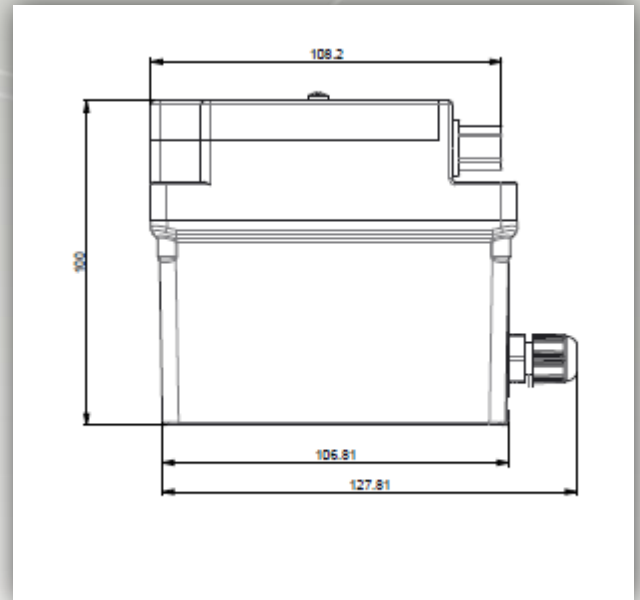
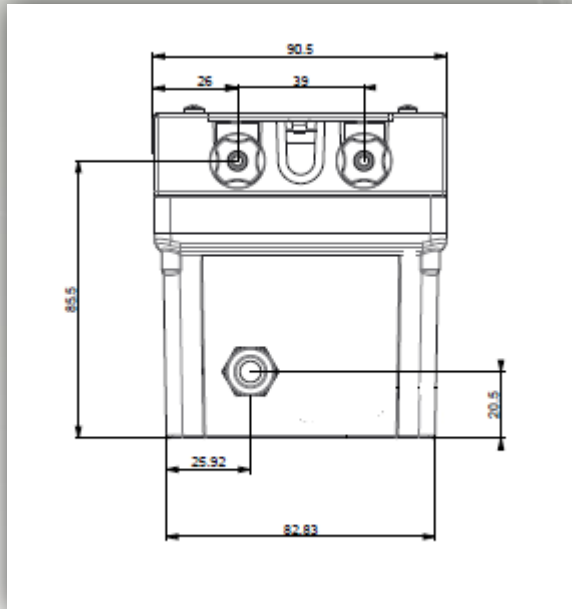

Cleaning System



Optional



0%5584NK

- silicon peristaltic hose

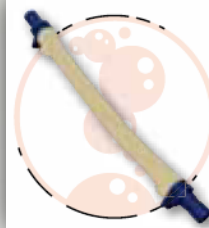

0%5569NKTL

- Santoprene peristaltic hose



Suction lance WITHOUT LEVEL
PROBE 8x12 45cm -pre assembled
PVC/PP suction lance with foot filter
(to avoid the pump sucks suspended
particles) and suction valve (to avoid
the suction tube's emptying)